

MULTI-AIRE IIP

POSITIVE AIR SUPPLY SYSTEM



MULTI-AIRE IIP

- IMPROVED COMFORT
- IMPROVED INDOOR AIR QUALITY
- FILTERED POSITIVE AIR FLOW
- VARIABLE SPEED W/CONTROLS
- WORKS WITH ALL TAMARACK AIREFORCE CONTROLS
- 6.6 CFM/WATT ENERGY USAGE (FILTERED)
- ONE 8" INLET AND FOUR 4" EXHAUST PORTS WITH GASKETS
- MAX. AIR FLOW OF 400 CFM (FILTERED)
- 120 VAC, 60HZ, .5 AMPS (AT FULL SPEED)
- MERV 13 FILTER

The Balanced Solution for Healthy Indoor Air Quality

In most homes, background ventilation is provided accidentally when air leaks through the building envelope. Accidental ventilation is unreliable. Not enough fresh air may enter during mild weather which can lead to poor indoor air quality. Home owners no longer accept the cold, drafty houses of the old days. Today, houses are expected to be cozy, draft free and energy efficient. A tight home is fine, as long as it comes with a controlled ventilation system. The Multi-Aire IIP is a low cost solution for supplying fresh air without those uncomfortable drafts and without the risk of excessive supply air. Fresh filtered air enters the home through a single intake and is then distributed through ducts to the living and sleeping areas.

Please call for pricing and availability.



320 Main Street • Buzzards Bay, Ma 02532
508-759-4660 / 800-222-5932 / Fax 508-759-6001

MULTI-AIRE II[®]

POSITIVE AIR SUPPLY SYSTEM

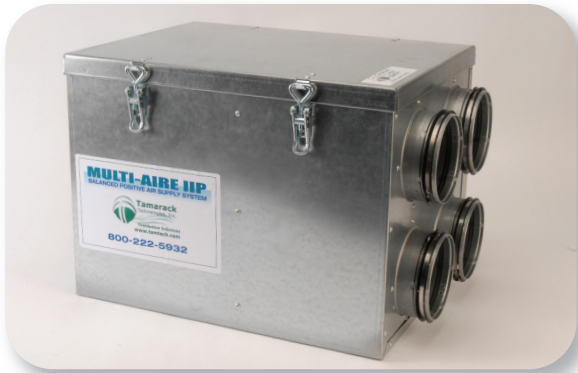

DIMENSIONS

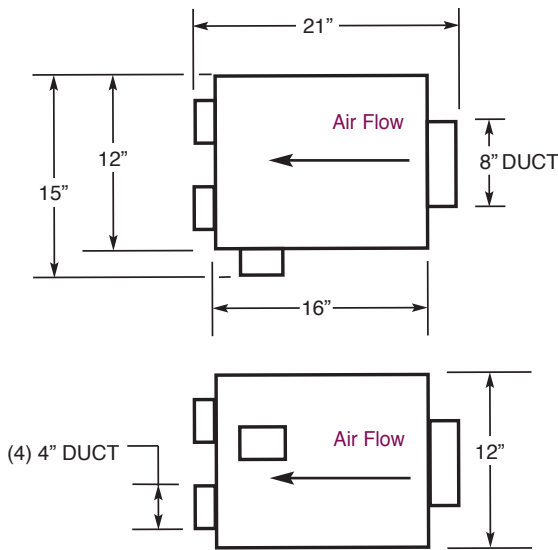

- DRAW IN OUTSIDE AIR
- DISTRIBUTE THE OUTSIDE AIR THROUGHOUT THE HOUSE
- CONTROL SYSTEM OPERATION AUTOMATICALLY
 - BECAUSE THE INTERIOR OF THE HOUSE IS SLIGHTLY PRESSURIZED, CONTAMINANTS FROM AN ATTACHED GARAGE, THE BASEMENT OR THE ATTIC ARE LESS LIKELY TO ENTER THE HOUSE
- BACK-DRAFTING OF COMBUSTION APPLIANCES IS ALSO LESS OF A RISK

SPECIFICATIONS

Electrical	
Voltage	115 VAC 60Hz
Power	Full Speed 60W.
Air Flow	400 CFM (Filtered)
Weights	Fan: 13 Lbs. Shipping: 23 Lbs.
Filter	MERV 13
Inlet	8" with Gasket
Outlet	(4) 4" with Gaskets

Improved comfort. Homes with tight construction and balanced ventilation systems can have fewer drafts and a constant supply of outdoor air resulting in improved comfort.

Improved health. Stale air can cause health problems. It can be responsible for symptoms such as headaches, drowsiness, and respiratory problems. These symptoms are more common in homes with poor ventilation and moisture control. Continuously providing fresh air can result in the improved health and well being of the occupants.



320 Main Street • Buzzards Bay, Ma 02532
508-759-4660 / 800-222-5932 / Fax 508-759-6001

